

SWING-UP CONTROL OF AN INVERTED PENDULUM BY ENERGY-BASED METHODS

Kazunobu Yoshida

Department of Electronic and Control Systems Engineering,
Shimane University
1060 Nishikawatsu-cho Matsue, Shimane 690-8504, Japan
E-mail:kyoshida@ecs.shimane-u.ac.jp

Abstract: The mechanical energy of a pendulum whose pivot can move horizontally can be controlled according to signs of the pivot acceleration values. A servo design technique is proposed which can control the pivot acceleration considering a limited travel of the pivot. This control law is applied to the swing-up control problem for an inverted pendulum.

1 INTRODUCTION

Swinging up an inverted pendulum is an old and challenging problem in the field of nonlinear control study. An inverted pendulum, a cart and pendulum system, has a structure where the pendulum is hinged to the cart via a pivot and only the cart is actuated. The motion of the pendulum has to be controlled by moving the cart back and forth within a limited travel of the cart.

There have been many studies on this subject. The method using a feed-forward bang-bang control proposed in [1] is very sensitive to modeling error, noise, and disturbance and is not a reliable technique. The bang-bang control law with pseudo-state feedback developed in [2] was successfully demonstrated on a rotating-arm inverted pendulum system without a rail length restriction. It is not suitable for controlling a cart and pendulum system in which the rail length is finite. The energy-based methods developed in [3], [4], and [5] have the same design philosophy as the technique proposed in this note. However, the relationship between the energy control and the design of the servo system is not clear and the limitation of the cart travels is not considered in these methods. The sliding mode control method presented in [6] does not take into account a limited cart travel either. An algorithm for swing-up control demonstration is developed in [7] using a linear saturating feedback law with destabilizing gains, which works successfully within a limited cart travel. However, it has no theoretical backgrounds and requires a rule of trial and error to obtain a good controller.

In this note a new approach to swing-up control is proposed based on an energy control method. That is, noting that the energy of the pendulum can be controlled according to the sign condition of the cart acceleration, we develop a method for controlling the cart acceleration

under a limited travel of the cart. The design procedure of the controller that controls the energy of the pendulum is quite simple, which mainly consists of constructing a servo system having a low-pass property and using a sinusoidal reference input generated from the pendulum trajectory. When the pendulum is close to the inverted vertical, a full-state feedback controller takes over the control and stabilizes the whole system. Some results of an experimental investigation are shown to demonstrate the effectiveness of the proposed control law.

2 MATHEMATICAL MODEL

The mathematical model of the cart and pendulum system depicted in Fig.1 is described by

$$\ddot{r} = \frac{1}{M + m \sin^2 \theta} (-mg \cos \theta \sin \theta - ml\dot{\theta}^2 \sin \theta + u_r), \quad (1)$$

$$\ddot{\theta} = -\frac{g}{l} \sin \theta + \frac{\ddot{r}}{l} \cos \theta. \quad (2)$$

3 DESIGN METHOD

3.1 Energy control method

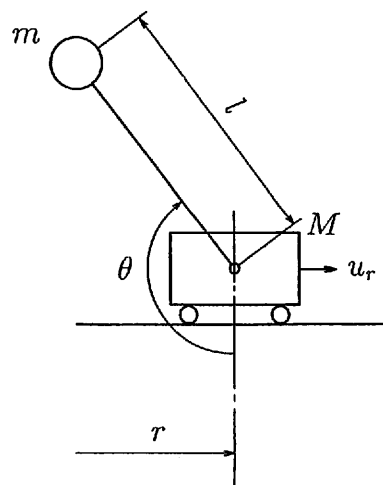

Fig.1 A cart and pendulum system

The mechanical energy of the pendulum and its time derivative are as follows:

$$V = \frac{1}{2}ml^2\dot{\theta}^2 + mgl(1 - \cos\theta), \quad (3)$$

$$\dot{V} = ml\dot{\theta} \cos\theta\dot{r}. \quad (4)$$

It is seen from equation (4) that V can be increased or decreased by changing the sign of \dot{r} in accordance with that of $\dot{\theta} \cos\theta$. If $\text{sgn}(\dot{r}) = \text{sgn}(\dot{\theta} \cos\theta)$ (resp. $\text{sgn}(\dot{r}) = -\text{sgn}(\dot{\theta} \cos\theta)$), then $\dot{V} > 0$ (resp. $\dot{V} < 0$). Since the travel of the cart is finite, \dot{r} has to be controlled in consideration of the constraint on r . The basic idea of the design method lies in constructing a servo system having a sinusoidal reference input, which is obtained from $(\theta, \dot{\theta})$, and generating \dot{r} satisfying the sign condition in order to control V to a prescribed value.

Let r_d be the reference input of the servo system for r , which will be given later. Using r_d , we put

$$u_r = (M + m \sin^2\theta)\{f_1(r_d - r) - f_2\dot{r}\} + mg \cos\theta \sin\theta + ml\dot{\theta}^2 \sin\theta. \quad (5)$$

Here f_1 and f_2 are given by

$$f_1 = \Omega^2, f_2 = 2\zeta\Omega, \Omega = \frac{\omega_n}{c_0}, \omega_n = \sqrt{\frac{g}{l}}, \quad (6)$$

so that the transfer function from r_d to r is represented by

$$G(s) = \frac{\Omega^2}{s^2 + 2\zeta\Omega s + \Omega^2}, \quad (7)$$

where ζ and c_0 are the design parameters. Let $g(\omega)$ and $\phi(\omega)$ be the gain and the phase lag of $G(j\omega)$, respectively.

Figure 2 shows a stabilized trajectory of the pendulum in the $\theta - \dot{\theta}/\omega_n$ plane. This coordinate system was chosen so that small free oscillations of the pendulum approximate circles. Without loss of generality, we assume that the angular displacement θ is represented in the range $[-\pi, \pi]$. As shown in Fig.2, we define the angle $\varphi(t)$ using the trajectory of the pendulum. We see that $\varphi(t)$ is a monotone increasing function of time t . Now consider the function being $-\sin\varphi(t)$ and note that this function has the same sign as $\dot{\theta} \cos\theta$ when $|\theta| \leq \pi/2$. In fact, we can utilize this function to construct a reference input for the servo system.

The reference input r_d is given by

$$r_d(t) = \frac{a}{g(\omega_n)} \sin(\varphi(t) - \pi + \phi(\omega_n)). \quad (8)$$

The parameter a determines the amplitude and sign of r_d . How to design a will be shown below. It is seen from simulations that when $|a|$ is small in comparison with l , $\varphi(t)$ can be approximated as

$$\varphi(t) = \omega'_n t + \varphi_0. \quad (9)$$

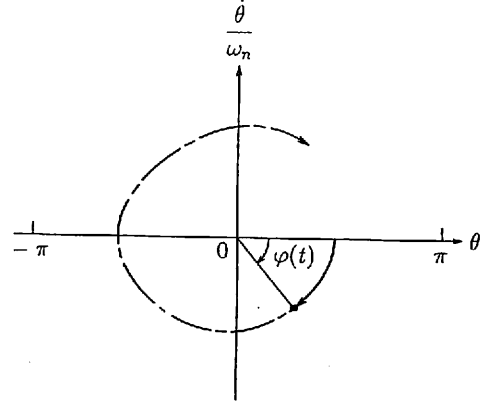

Fig.2 The $\theta - \dot{\theta}/\omega_n$ plane

The parameter ω'_n is a function of the amplitude of θ . When the amplitude is small, ω'_n is nearly equal to ω_n , and ω'_n becomes smaller as the amplitude of θ becomes larger. It should be noted that r_d is not a perfect sinusoidal function because $\varphi(t)$ is not an exact linear function of t . Therefore, r_d has higher harmonics in addition to the fundamental component of frequency ω'_n . These higher harmonics would disturb the sign condition of \dot{r} . However, when c_0 is given large to some extent, the servo system works as a low-pass filter and the higher harmonics are diminished. Then, when the servo system comes to the steady state, we have

$$r \simeq \frac{ag(\omega'_n)}{g(\omega_n)} \overline{\sin}(\varphi(t) - \pi + \phi(\omega_n) - \phi(\omega'_n)), \quad (10)$$

$$\dot{r} \simeq \frac{ag(\omega'_n)}{g(\omega_n)} \omega_n^2 \overline{\sin}(\varphi(t) + \phi(\omega_n) - \phi(\omega'_n)), \quad (11)$$

where $\overline{\sin}(\cdot)$ means the fundamental component of $\sin(\cdot)$. We can see from equation (10) that a has to be chosen so that the amplitude of r satisfies the constraint, and from equation (11) that when $\phi(\omega_n) \simeq \phi(\omega'_n)$, \dot{r} and $\overline{\sin}(\varphi(t))$ are in phase, i.e., the sign condition of \dot{r} is also satisfied. It can be seen from simulations that \dot{r} and $\dot{\theta} \cos\theta$ have mostly the same sign when $|\theta| \leq \pi/2$. As far as the sign of \dot{V} is concerned, $\dot{V} < 0$ (resp. $\dot{V} > 0$) when $a > 0$ (resp. $a < 0$). In order to make V converge to the reference energy, say V_d , the parameter a is given by

$$a = \begin{cases} a_0 \text{sgn}(V - V_d) & \text{if } |V - V_d| \geq b_0 \\ a_0(V - V_d)/b_0 & \text{if } |V - V_d| < b_0 \end{cases}, \quad (12)$$

where $a_0 > 0$ and $b_0 > 0$ are the design parameters. We see that a_0 relates to the amplitude of r . Actually a_0 is chosen smaller than the desired amplitude because $g(\omega'_n) \geq g(\omega_n)$. According to (12), the amplitude of a is decreased as V approaches V_d . The parameter b_0 is a number that determines the time when the amplitude of a is decreased. The time is delayed more if a smaller b_0 is

given. These parameters are determined by performing simulations.

In case of the swing-up control, V_d is equal to the potential energy of the pendulum at the upward vertical position, i.e.,

$$V_d = 2mgl. \quad (13)$$

Although θ enters the region of $\pi/2 < |\theta| \leq \pi$ during the swing-up control, where the sign condition of \dot{r} is not satisfied, the control law stated above can be used for the swing-up control since $|\dot{V}|$ is small in this region.

The proposed energy control law is given by equations (5),(8),and (12). As for the parameters ζ and c_0 , from simulations we have the following as a criterion:

$$\zeta = 0.7 \sim 1.5, \quad c_0 = 0.5 \sim 2. \quad (14)$$

Actually, these parameters are to be tuned by considering the specifications of the servo system, such as the limitation of the motor torque.

3.2 Stabilizing control near the upward equilibrium point

Since the pair $(\theta, \dot{\theta})$ that makes $V = V_d$ is not unique, the upward equilibrium point cannot be stabilized with the energy control. Thus we should switch the control law to a linear one when $(\theta, \dot{\theta})$ approaches the equilibrium point, i.e., $(\pm\pi, 0)$. We use the following conditions as a criterion for switching:

$$|V - V_d| < \epsilon_1, \quad 1 + \cos \theta < \epsilon_2, \quad (15)$$

where ϵ_1 and ϵ_2 are small, positive constants, which are determined by simulations so that the switch is done smoothly. The stabilizing control law is designed by applying the LQ methods to the model linearized at the upward equilibrium point, i.e.,

$$(\tau, \dot{r}, \theta, \dot{\theta}) = (0, 0, \pi, 0). \quad (16)$$

4 EXPERIMENTAL RESULTS

The transfer function from u_r to r (both represented in volts), the equivalent length of the pendulum, and the design parameters are as follows:

$$G(s) = \frac{1.21}{s(1 + 0.32s)}, \quad l = 0.227\text{m}, \quad (17)$$

$$\zeta = 1.2, \quad c_0 = 0.9, \quad a_0 = 0.8[\text{V}], \quad b_0 = 0.833. \quad (18)$$

Figure 3 shows the results of the experiments, where the pendulum is swung up from the pendant position to the upright one. It is seen that the energy is controlled as keeping the amplitude of the cart small.

5 CONCLUSIONS

An approach to the swing-up problem of an inverted pendulum has been developed using a technique that can control the energy of the pendulum, and some results of

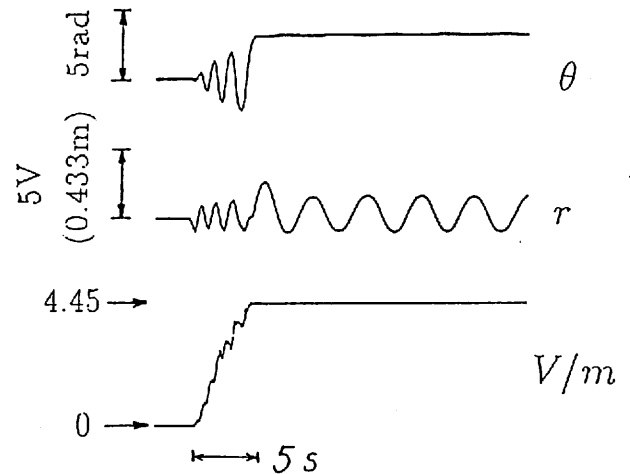

Fig.3 The results of experiments

experiments are given which shows the effectiveness of the proposed control law.

The present design technique was also used in [8] to find a stabilizing control law for a crane system having a restricted travel.

References

- [1] M.Mori, H.Nishihara, and K.Furuta, "Control of unstable mechanical system -Control of pendulum", *INT.J.CONTROL*, vol.23, no.5, pp.673-692, 1976.
- [2] K.Furuta, M.Yamakita, and S.Kobyashi, "Swing-up control of inverted pendulum using pseudo-state feedback", *Journal of Systems and Control Engineering*, vol.206, pp.263-269, 1992.
- [3] M.Wiklund, A.Kristenson, and K.J. Åström, "A new strategy for swinging up an inverted pendulum", *The 12th IFAC World Congress*, vol.9, pp.151-154, 1993.
- [4] M.W.Spong, "Energy based control of a class of under-actuated mechanical systems", *The 13th IFAC World Congress*, pp.431-435, 1996.
- [5] A. Bradshaw and J.Shao, "Swing-up control of inverted pendulum systems", *Robotica*, vol.14, pp.397-405, 1996.
- [6] A. Inoue, K.Nakayasu, and S.Masuda, "A swingup control of an inverted pendulum using a sliding mode control", *The 3rd International Conference on Motion and Vibration Control*, pp.449-454, 1996.
- [7] Quanser Consulting Inc., "Self-erecting linear-motion inverted pendulum", A manual for the algorithm for demonstration, 1996.
- [8] K.Yoshida, "Nonlinear controller design for a crane system with state constraints", *1998 American Control Conference*, pp.1277-1283, 1998.